

MERIS DIFFUSER CALIBRATION AT TNO TPD (SYNTHESIS OF THE RESULTS 1996-2002)

G. Bazalgette Courrèges-Lacoste⁽¹⁾, J. Groote Schaarsberg⁽²⁾, C. Van Eijk-Olij⁽³⁾

(1) TNO TPD, P.O. Box 155, 2600 AD Delft, The Netherlands.
bazalgette@tpd.tno.nl

(2) TNO TPD, P.O. Box 155, 2600 AD Delft, The Netherlands
Schaarsberg@tpd.tno.nl

(3) TNO Space, P.O. Box 155, 2600 AD Delft, The Netherlands
vaneijk@tpd.tno.nl

1 SUMMARY

The Medium Resolution Imaging Spectrometer (MERIS) is an instrument of the ENVISAT-1 payload, launched in March 2002. It will provide the user community with an advanced sensor for the remote assessment of marine phenomena and processes that dominate about three quarters of the Earth's surface and play a crucial role in shaping its climate and ecology.

In order to satisfy the severe radiometric and spectrometric performance requirements, the instrument is equipped with a calibration system consisting of flat panel diffusers illuminated by the sun. The calibration hardware is implemented on a rotating disk, installed into the MERIS field of view at the cross over point of the five cameras, in order to select any of the five positions of the disk. Within these five positions, two correspond to radiometric calibrations using *Spectralon* diffusers, which have been selected as material diffuser for radiometric reference.

This document presents the synthesis of the calibration work, performed at TNO TPD on these two MERIS on-board diffusers and on additional *Spectralon* diffusers dedicated to the calibration of MERIS. The measurements were performed between 1996 and 2002, in three distinct measurements campaigns. Additional to the BRDF characterization work, we report in this document the result of the validation of the TNO TPD BRDF measurement facility. The validation was done in an intercalibration BRDF measurement of one of the MERIS diffuser, between NASA GSFC and TNO TPD. Finally the measurement of the BRDF of a degraded spectralon diffusers, the modeling of the BRDF before and after degradation and the implementation of the corresponding model to the MERIS geometry are presented.

2 INTRODUCTION

Light diffusers are used in remote sensing applications as independent onboard secondary calibration standards. Calibration of the diffusers is performed prior to deployment by calibration measurements of the bi-directional reflection function (BRDF) under illumination and detection conditions as will occur in flight. Light from e.g. the sun can be used in flight as a reference light source and the optical system is occasionally compared with the original calibration results to monitor the performance of the instrument.

In the recently launched earth observing satellite ENVISAT (deployment March 2002) the 'Medium Resolution Imaging Spectrometer' (MERIS) detects fifteen spectral bands of variable central wavelength and bandwidth between 390 nm to 1040 nm. Its primary mission is the study of ocean color, however it has a strong potential for use over terrestrial surfaces and atmospheric applications.

MERIS is a high performance autonomous instrument that will monitor the Earth-diffused solar flux with a radiometric accuracy of 2%. It is a medium resolution (260 m and 1 km in nadir) imaging spectrometer with a swath width of 1100 km for the total 68.5° field of view (the FOV is divided between five identical cameras, each having a field of view of 14°). Five cameras simultaneously record data over 15 (visible and near infrared) spectral bands programmable in width (minimum width : 1.25 nm) and position, with a very low degree (0.3 %) of polarization sensitivity.

The basic hardware requirements for an on-board calibration system offering both a uniform reference signal over a large field of view and a stable absolute spectral reference signal has led to a preferred solution which utilizes diffuser plates illuminated by the sun. The diffusers are made of *Spectralon*; a translucent tetrafluoroethylene based polymer, a well-established secondary reflection standard in radiometric applications.

The calibration hardware is implemented on a selection disk. A stepper motor allows the selection of any of the five positions of the disk as required by the instrument mission requirements. Within these five disk positions, two are dedicated to radiometric calibration :

- For the radiometric calibration process, about every three weeks, a *Spectralon* diffuser plate is inserted into the field of view of MERIS at the cross over point of the five cameras' fields of view. The diffuser provides a reflectance standard across the entire spectral range and field of view. In this way a full aperture instrument calibration, which follows the same optical path as in the observation modes is realized.

-. A second *Spectralon* diffuser, dedicated to diffuser degradation monitoring, is exposed to the sun for a cumulated period of about 1 hour during the MERIS lifetime. Because some limited degradation caused by radiation exposure may be expected this second diffuser is provided to evaluate changes in the BRDF of the commonly used diffuser. This diffuser will be used infrequently and will thus not degrade as quickly as the first diffuser. Comparing the data acquired with both diffusers monitors the aging of the radiometric diffuser.

The TNO TPD in Delft has performed the calibration measurements of the BRDF of the two on-board *Spectralon* diffusers of MERIS between 1996 and 2002. The results are used in the validation of the MERIS instrument.

This document is the synthesis of this calibration work performed between 1996 and 2002 on the MERIS on-board diffusers and additional *Spectralon* diffusers.

During the calibration campaign of 1996 (see part 3) a total of five diffusers were calibrated (in three phases) using the TNO TPD calibration facility. Furthermore, two additional diffusers were measured that are not used for the MERIS calibration. The diffusers (manufactured by Labsphere) were numbered as follows :

- Diffuser #2 measured in October 1995. The measurements included measurements on the polarization dependence of the *Spectralon* BRDF and measurements of the specular component at 65°.
- Diffusers #11 and #12 measured from November 1995 to February 1996. The measurements consisted of spectral dependence and spatial dependence measurements. These diffusers served as qualification model and are referred to as QRR1 and QRR2 respectively.
- Diffusers #18 and #19 measured from August 1996 to September 1996. The measurements consisted of spectral dependence and spatial dependence measurements. These diffusers are the MERIS flight model diffusers, referred to as FRR1 and FRR2 respectively.
- Diffusers #21 and #23 measured in October 1996. For the purpose of cross calibration, ESA has requested from the manufacturer (Labsphere) two diffusers identical to the MERIS flight models. These diffusers are named ESA diffusers not to confuse them with the MERIS FRR diffusers.

In 2000, the MERIS dedicated setup of TNO TPD allowing out-of-plane measurements was updated and used to perform additional BRDF measurements from the MERIS calibration grid for modeling purpose on the ESA diffuser

#23. Also additional BRDF measurements, which were a partial repetition of the previous measurements of 1996, were performed to check the stability of the *Spectralon* diffuser with respect to time (part 4). Furthermore, an intercalibration of the MERIS ESA diffuser #21 was performed between TNO TPD and NASA GSFC to validate the TNO TPD calibration facility (part 5).

In 2002, a new setup (measuring BRDF in the plane of incidence), was used to check again the stability of the ESA diffuser (#21 & #23) with respect to time. The same setup was used to perform some BRDF measurements of the degradation (silicone deposit under UV irradiation) of a 2-inch Spectralon sample propriety of ESA. Finally, we performed at TNO TPD in collaboration with the University of Amsterdam a modeling study designed to simulate the degradation of the MERIS diffuser in space. The modeled effect of the degradation is implemented in the MERIS geometry (part 6).

The work has been presented in internal reports [1] to [8] as part of the ESTEC MERIS project.

3 1996 - CHARACTERIZATION IN THE MERIS CALIBRATION GRID

3.1 Calibration requirements

The radiometric performance requirement is one of the most crucial requirements that MERIS has to meet because the signals coming from the ocean are weak and thus most difficult to detect and quantify. In MERIS the sun-normalized spectral radiance of the Earth surface has to be determined accurately in order to achieve reliable data products. This is done by comparing the MERIS observations of the sun-lit Earth with MERIS observations of a sun-lit onboard diffuser. The diffuser is in this way a BRDF reference with which the BRDF of the Earth is compared. This method only works when the BRDF of the onboard diffuser is accurately known under all geometric conditions as experienced in MERIS. The five MERIS cameras observe different parts of the 200 mm x 40 mm onboard diffuser at different angles. The associated position and angle dependence of the BRDF are determined during the calibration campaign. Parameters, which have been varied during this campaign, include:

- angle of incidence, γ , of the incident light ranging from 64.72° to 66.29° (orbital effect).
- azimuthal angle, β , of incidence ranging from 21.1° to 35.15° (seasonal effect)
- wavelength within the range 390-1040 nm.
- angle of observation of the scattered spectral radiance, δ , ranging from -34.3° to $+34.3^\circ$.
- position (instantaneous field-of-view) on the diffuser w.r.t. the center of the long axis of the diffuser from -70 to +70 mm.

3.2 Measurement campaign 1996

The TPD Absolute Radiometric Calibration Facility (ARCF) is located in a class 100 clean room (see Fig. 1). The wavelength-tunable light beam is created by a SuperQuiet Xe lamp or a quartz tungsten-halogen lamp, a computer-controlled double prism monochromator (that can transmit any spectral band within the 240 nm - 2400 nm region) and a collimator

During the first measurement campaign of 1996, the MERIS qualification model diffusers (i.e. QRR1 and QRR2), the onboard diffusers for MERIS (FRR1 and FRR2), and the ESA diffusers (ESA #21 and ESA #23), were calibrated using the MERIS dedicated setup of TNO TPD allowing out-of-plane measurements for all applicable angles of incidence and observation (Fig. 2). After extensive commissioning the accuracy was determined to be $< 0.5\%$ (1σ) for the absolute BRDF measurements and of the order of 0.3-0.4% for the relative measurements (see Table 1). Parallel to the calibration activity the MERIS test diffuser (#2) was used to quantify the polarization dependence of the BRDF and the specular component both for 65° angle of incidence.

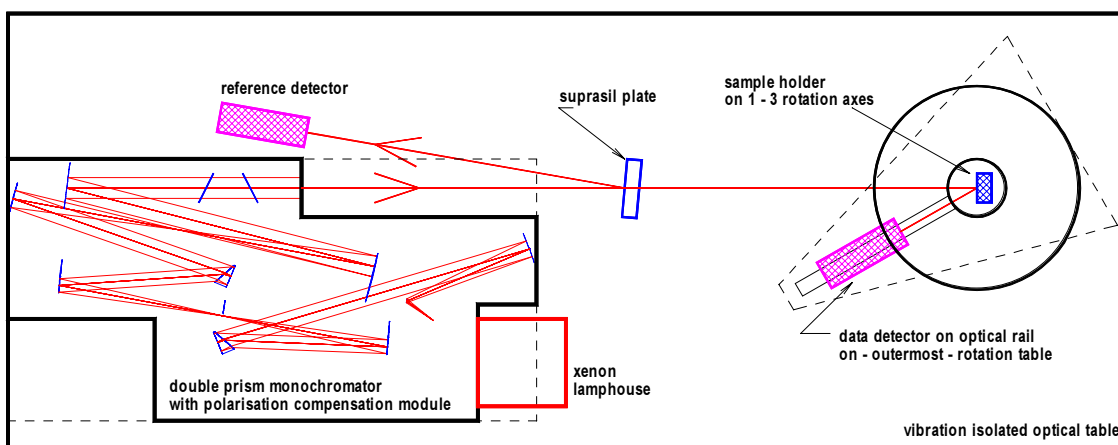

Fig. 1 : schematic view of the ARCF calibration facility. The figure shows the setup of 2002, which is equivalent to the setup of 1996, although the monochromator and detectors have been updated.

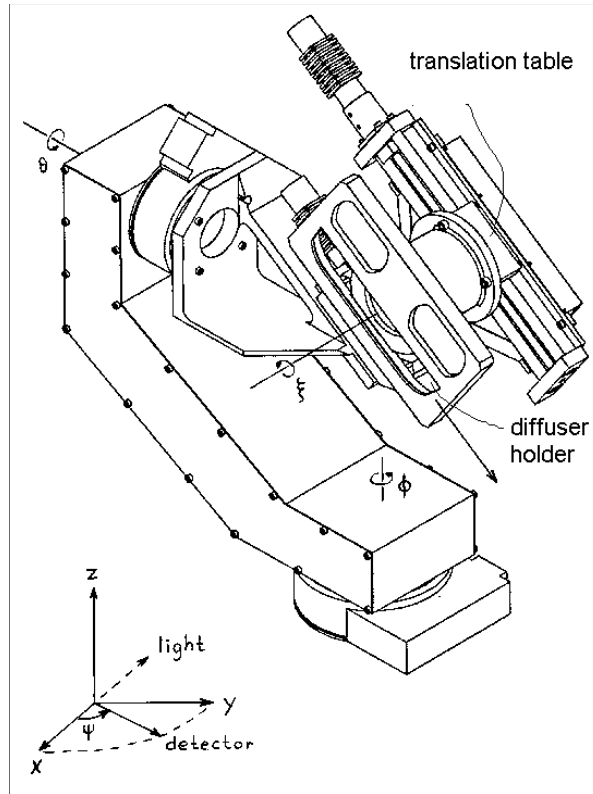

Fig. 2: rotation/translation setup for BRDF measurements of 1996 and 2000.

Table 1 : The error budget; SB: sign-biased error; NSB: non-sign-biased error; R: random error. The errors are summed as follows:

$$\text{Total error } (1\sigma) = |\sum SB_i| + \sqrt{[\sum NSB_j^2/3 + \sum \sigma_k^2]}$$

Error source (x_i)	Absolute BRDF	Relative spatial	Relative spectral
FOV (NSB)	< 0.2 %	-	-
Angular precision (R)	0.1 %	0.1 %	-
Detector linearity (R)	0.3 %	-	0.3 %
Beam uniformity			
SB	-0.15 %		
NSB	0.35 %	0.2%	0.2%
Noise (R)	0.2 %	0.2 %	0.2 %
Polarization (NSB)	<0.05 %	<0.01 %	<0.02 %
Stray light:			
SB	+0.1 %		
NSB	0.1 %	0.1 %	0.1 %
Total error (1σ)	0.49 %	0.26 %	0.38 %

For the used angles of incidence, which lie in the 65° region, and when changing the observation angle within the 68.5° MERIS field-of-view, deviations from ideal Lambertian behavior were observed to be of the order of 10% (peak-to-peak). However, this non-Lambertian behavior does not introduce problems as long as the diffusers are carefully calibrated (Fig. 3). When varying the wavelength while keeping the geometry fixed, the BRDF was measured to be constant within 1% (Fig. 4). Uniformity of the BRDF across the diffuser surface received special attention: for the flight diffusers FRR deviations from perfect surface uniformity were smaller than 0.5% (while the deviation amounts up to 1 % for the qualification model diffusers). An azimuthal dependence of up to 3 % was observed when the azimuth angle was varied from 21.1° to 35.15°.

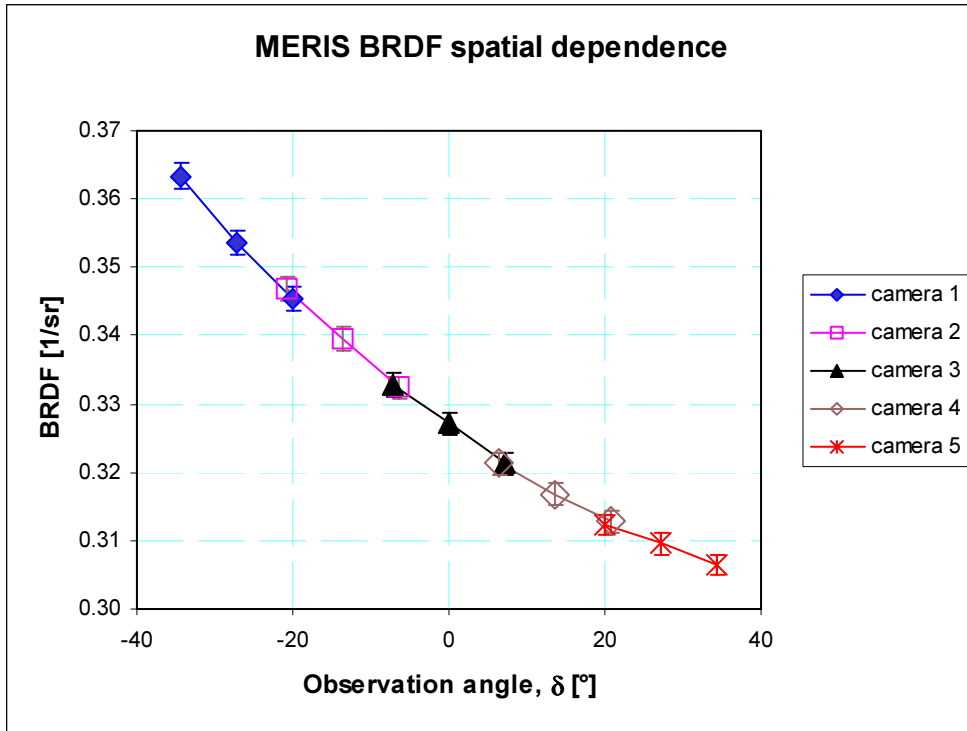

Fig. 3: BRDF variation of diffuser FRR # 18 within the MERIS FOV (corresponding to the five MERIS cameras and their respective field of view). $\gamma = 65.35^\circ$, $\beta = 27.5^\circ$, $\lambda = 560$ nm. Errors bars are $\pm 1 \sigma$.

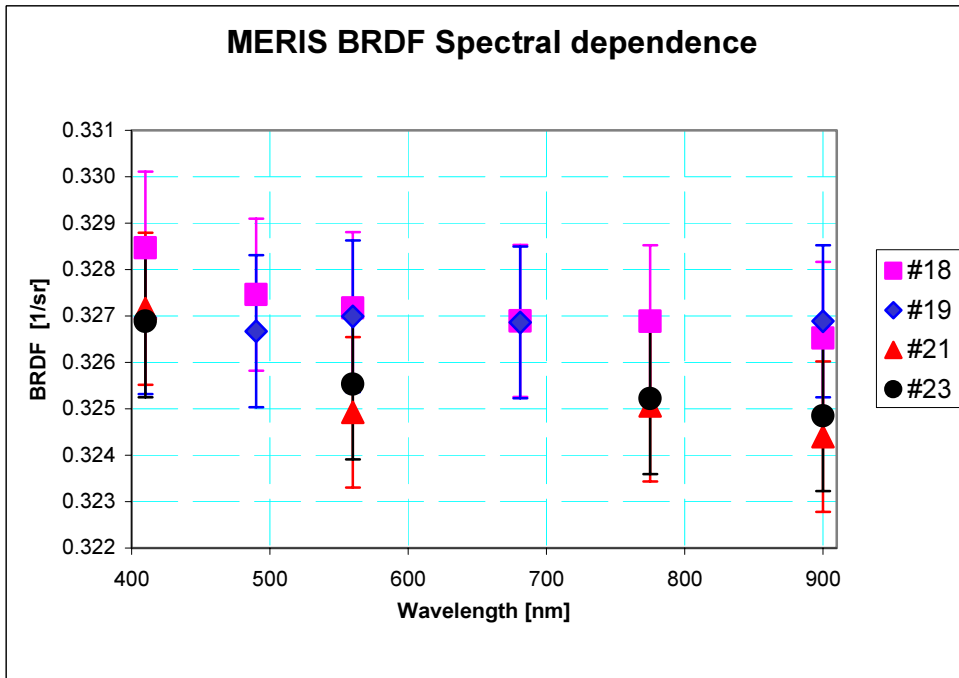

Fig. 4 : spectral dependence of the BRDF of diffusers FRR1, FRR2, ESA. $\gamma = 65.35^\circ$, $\beta = 27.5^\circ$, $\delta = 0^\circ$. Errors bars are $\pm 1 \sigma$.

4 2000 – ADDITIONAL BRDF MEASUREMENTS & CHARACTERIZATION OF THE DIFFUSERS OUT OF THE MERIS CALIBRATION GRID :

In 2000, the MERIS dedicated setup of TNO TPD allowing out-of-plane measurements was updated and used to perform additional BRDF measurements out of the MERIS calibration grid for modeling purpose on the ESA diffuser #23. We had no major deviations in the measurement setup with respect to 1996, nor do we have any non-conformity. Referring to the error budget as prepared for the MERIS measurements we expect an error of 0.5% (1σ) for the absolute BRDF value

Also additional BRDF measurements, which were a partial repetition of the previous measurements of 1996, were performed to check the stability of the *Spectralon* diffuser with respect to time. Referring to the error budget as prepared for the MERIS measurements of 1996, the expected error was of 0.5% (1σ) for the absolute BRDF value. Comparison of BRDF values with the results from 1996 shows that all the values are identical considering a margin $\pm 3\sigma$ (1.5 %). From the wavelength scan results (Fig. 5 & Fig. 6), it doesn't appear in the visible and NIR any significant deviation with respect to the measurements of 1996, while a variation of $\approx 1\%$ in the wavelength UV range is present.

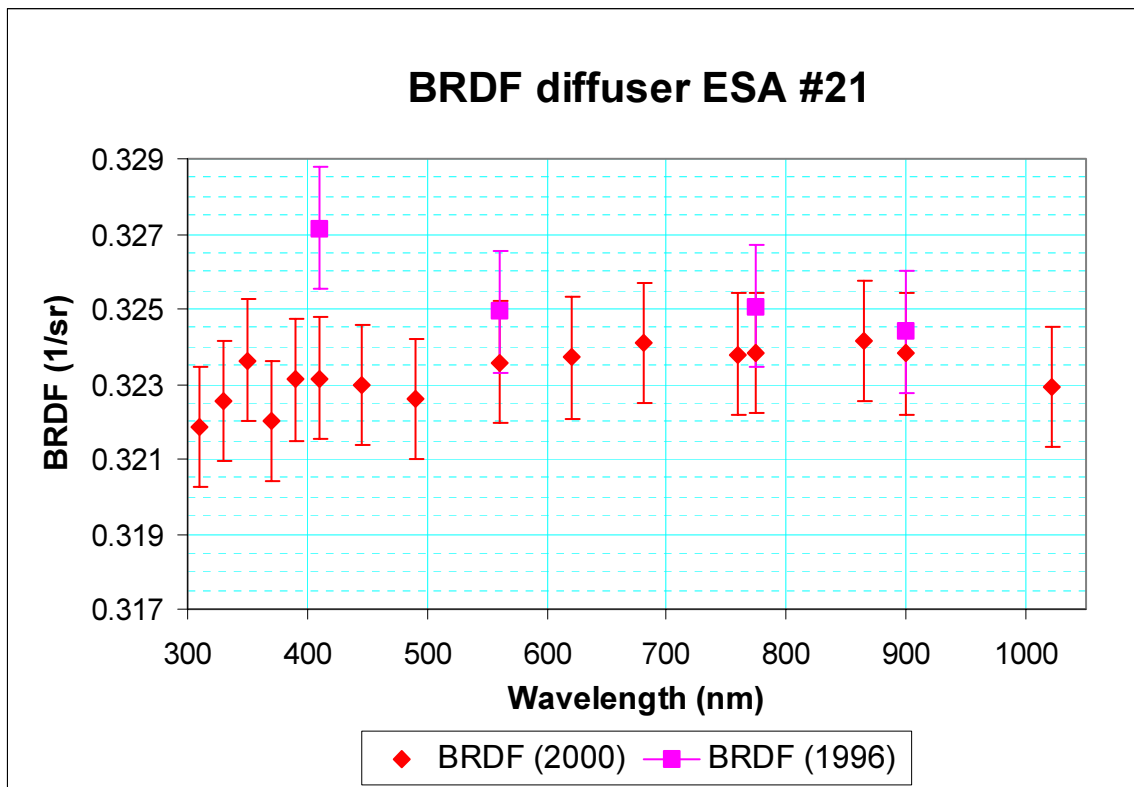

Fig. 5 : ESA diffuser # 21. Comparison of BRDF wavelength dependency measurements of 1996 and 2000. $\gamma = 65.35^\circ$, $\beta = 27.5^\circ$, $\delta = 0^\circ$. Errors bars are $\pm 1\sigma$.

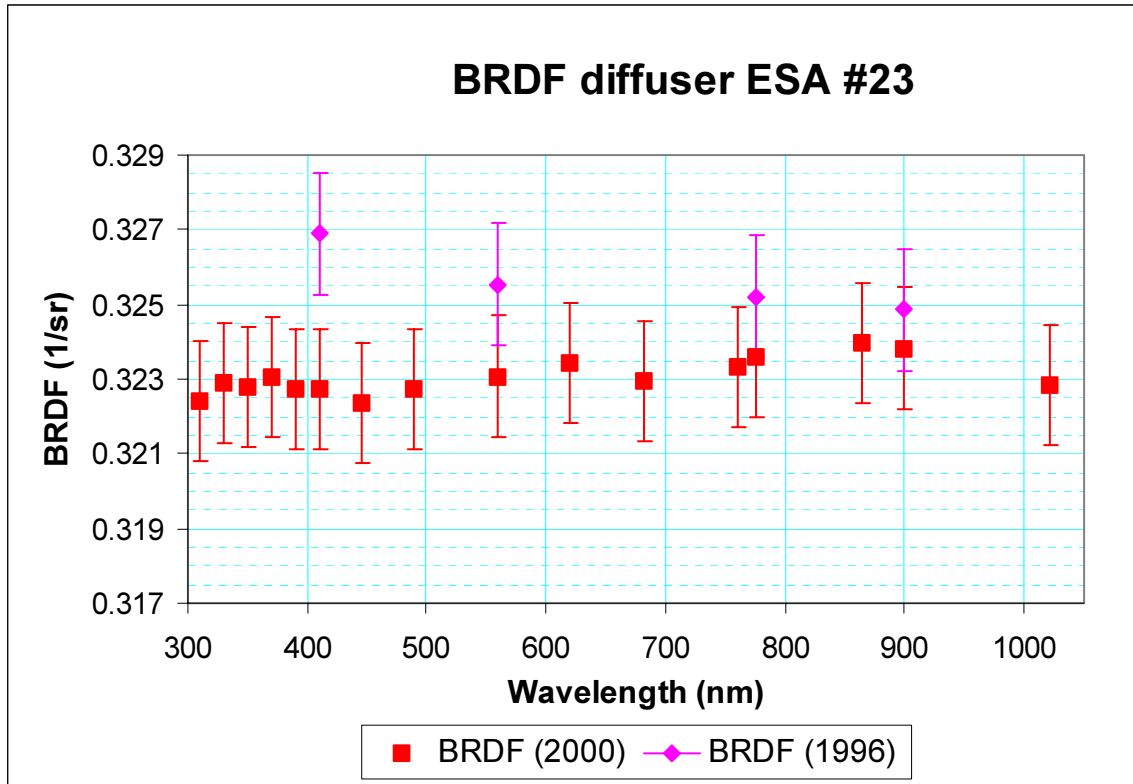

Fig. 6 : ESA diffuser #23. Comparison of BRDF wavelength dependency measurements of 1996, and 2000. $\gamma = 65.35^\circ$, $\beta = 27.5^\circ$, $\delta = 0^\circ$. Errors bars are $\pm 1 \sigma$.

5 2000 – VALIDATION OF THE TNO TPD SETUP BY INTER-COMPARISON WITH NASA GSFC :

An intercalibration of the MERIS ESA diffuser #21 was performed between TNO TPD and NASA GSFC in 2000. The comparison of BRDF measurements agreed within 1.5% maximum peak-peak for all angles and wavelength (see Fig. 7 and Fig. 8). These measurements are well within the measurement uncertainty ($1\sigma = 0.5\%$) of TNO TPD for measurements of 2000 and 2002, within the MERIS spectral range 390-1040 nm.

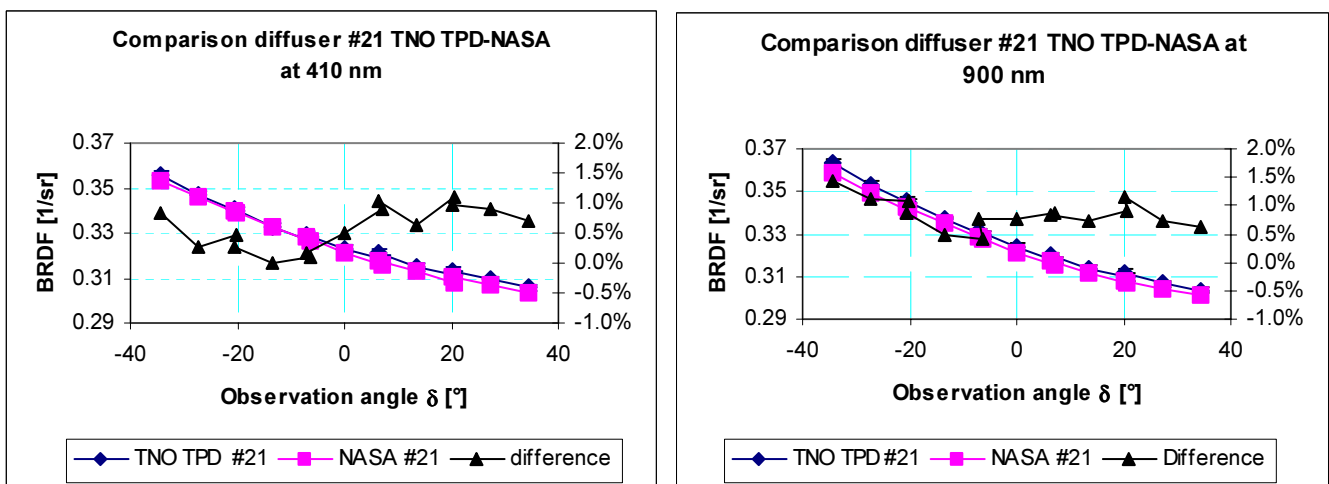

Fig. 7 : BRDF comparison measurement TNO TPD-NASA at 410 nm & 900 nm. $\gamma = 65.35^\circ$, $\beta = 27.5^\circ$.

6 2002 – ADDITIONAL BRDF MEASUREMENTS & SPACE ENVIRONMENT DEGRADATION OF A 2-INCH SPECTRALON DIFFUSER

In 2002, a new setup (measuring BRDF in the plane of incidence), which was just commissioned and shown compliant with the very strict requirements of OMI, was used to check again the stability of the ESA diffuser (#21 & #23) with respect to time. We have found no major deviations in the measurement setup with respect to the error budget as prepared for the MERIS measurements, nor did we find any non-conformances. This measurement setup has the capability of obtaining a BRDF of the MERIS *Spectralon* diffuser with an accuracy of 0.5% (1σ).

The comparison of BRDF values of 2000 and 2002 measured at TPD for diffuser #23 and #21 with those of 2002 shows that all the values are identical in the range 390-900 nm considering a margin of $\pm 1\sigma$. Furthermore, a slight wavelength dependency ($\leq 1\%$) appears again in the UV range (point at 350 nm) for both diffusers (see for e.g. diffuser #21, Fig. 8).

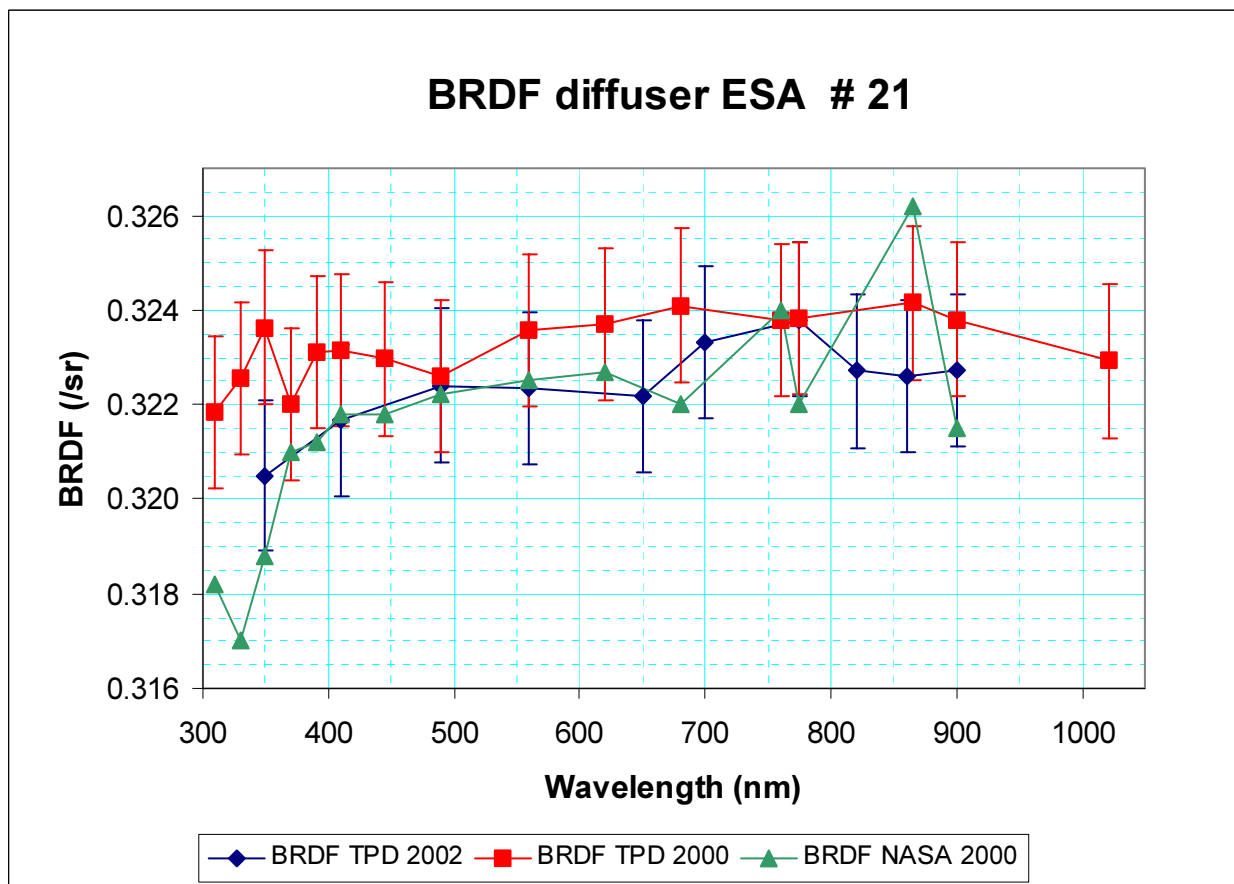

Fig. 8 : Wavelength dependence of the BRDF of the ESA diffuser # 21. Comparison of the TPD measurements of 2000 and 2002 with NASA 2000. $\gamma = 65.35^\circ$, $\beta = 27.5^\circ$ or 29° , $\delta = 0^\circ$. Errors bars are $\pm 1\sigma$.

The same setup was used to perform some BRDF measurements of the degradation (silicone deposit under UV irradiation) of a 2-inch Spectralon sample propriety of ESA. The most dominant effect of the degradation is a shift of the relative BRDF curve (*i.e.* ratio BRDF after irradiation to the BRDF before irradiation) downwards for wavelength in the UV due to absorption (Fig. 9). This is to be expected for a thin strongly absorbing top. An other remarkable effect is the apparent enhanced reflection at large observation angle (observation in the forward scattering direction) that can be due to interplay between absorption and the change of refractive index and/or mean free path.

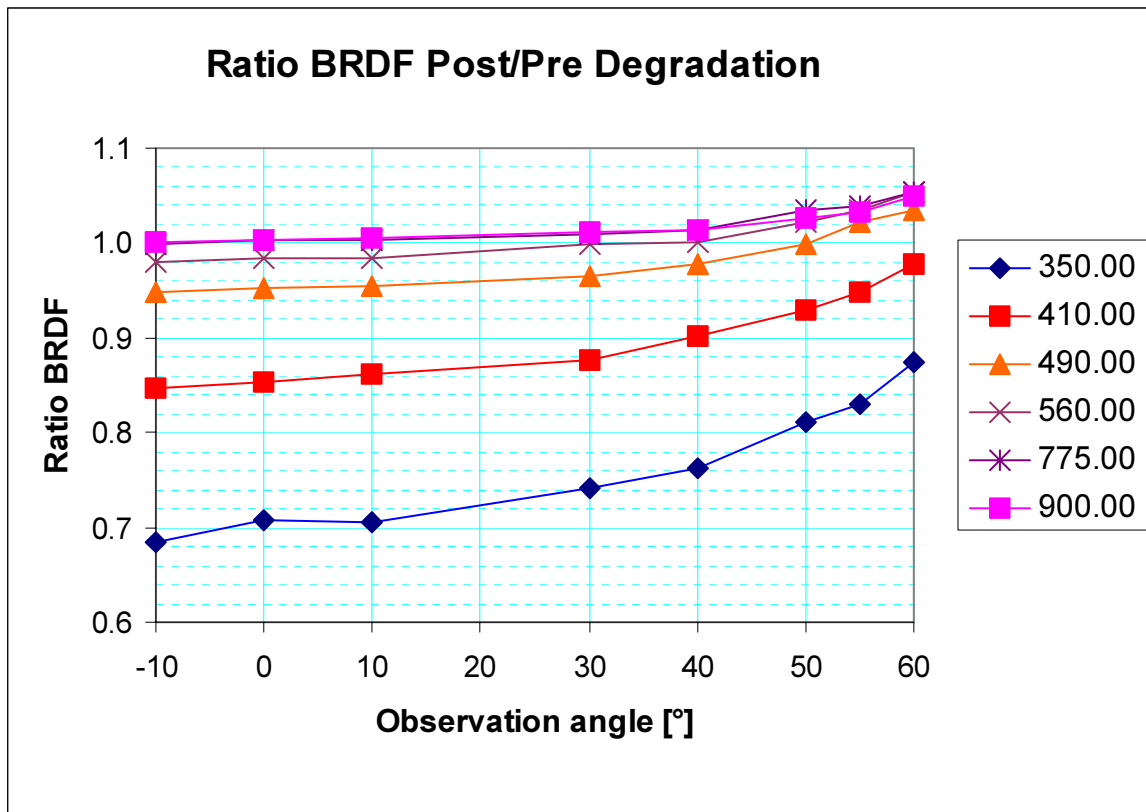

Fig. 9 : Ratio of the BRDF of the 2-inch Spectralon diffuser before and after the irradiation. $\gamma = 65.35^\circ$, $\beta = 29^\circ$.

Finally, in 2002, we performed at TNO TPD in collaboration with the University of Amsterdam a modeling work of the degradation of the MERIS diffuser in space environment (silicone deposit under UV irradiation). The effect of the modeled degradation corresponds, in the MERIS geometry, to a shift of the BRDF to the lower values for the UV and visible range. Remarkably, in the NIR spectral range (i.e. 900 nm) the BRDF remains almost constant in the backward scattering direction and even increases in the forward scattering direction.

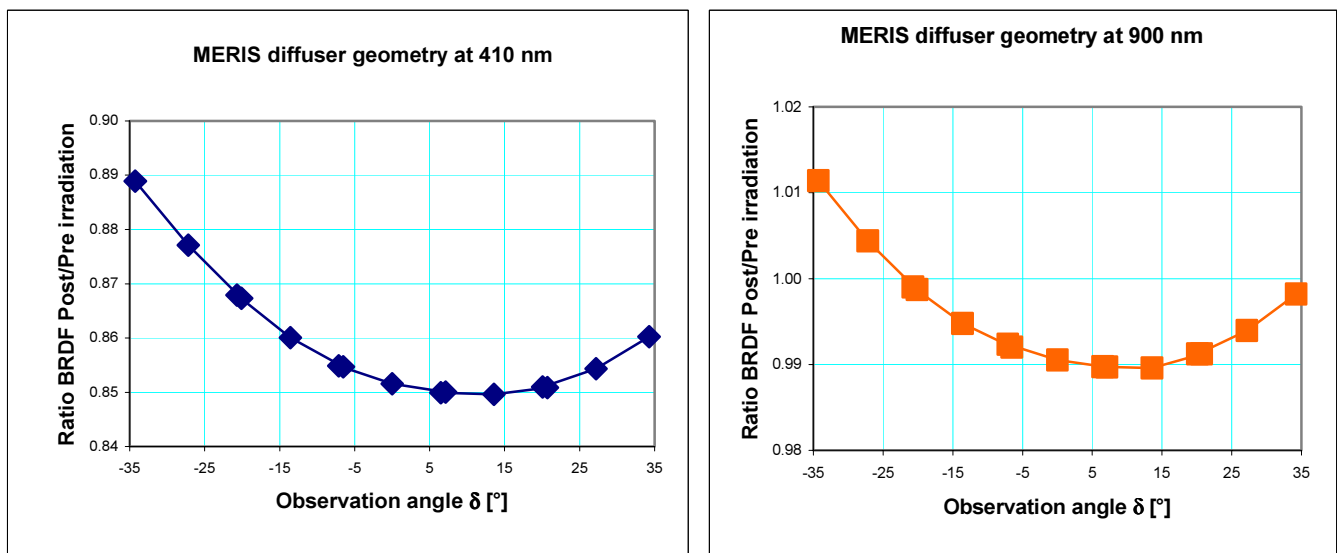

Fig. 10 : Model based ratio of the BRDF before and after degradation implemented in the MERIS nominal geometry. For $\gamma = 65.35^\circ$ and $\beta = 27.5^\circ$.

7 CONCLUSION

Spectralon diffusers for MERIS were calibrated using two setups at TNO TPD :

- the first one, used in 1996 and 2000, allowed out-of-plane measurements for all applicable angles of incidence and observation. After extensive commissioning the accuracy was determined to be $< 0.5\%$ for the absolute BRDF measurements and of the order of 0.3-0.4% for the relative measurements. The MERIS diffusers characterized in 1996 were the two flight models, the two qualification models, the two ESA diffusers (same BRDF characteristics than the flight models), and a test diffuser dedicated to polarization measurements. For the used angles of incidence, which lie in the 65° region, and when changing the observation angle within the 68.5° MERIS field-of-view, deviations from ideal Lambertian behavior were observed to be of the order of 10% (peak-to-peak). When varying the wavelength while keeping the geometry fixed, the BRDF was measured to be constant within 1%. Uniformity of the BRDF across the diffuser surface received special attention: for the flight diffusers deviations from perfect surface uniformity were smaller than 0.5%. Polarization dependence of the BRDF of the studied *Spectralon* material was measured and still amounts to several percent for the 65° angle of incidence. An azimuthal dependence of up to 3 % was observed when the azimuth angle was varied from 21.1° to 35.15° . In 2000 the BRDF of MERIS ESA diffuser was measured again with the same but updated setup (same error budget than in 2000). The BRDF was found identical to that of the same diffusers measured in 1996, considering a $\pm 3\sigma$ error margin. Furthermore, BRDF measurements out of the MERIS calibration grid were performed in 2000 for modeling purpose.

- the second setup, used in 2002 to measure again the BRDF of the MERIS ESA diffuser, allowed in-plane only BRDF measurements. Its error budget was found identical to that of the setup of 1996 ($1\sigma = 0.5\%$). The wavelength dependence of the BRDF of the ESA diffuser was found identical to that of 2000 in the spectral range 390-1040 nm, considering a $\pm 1\sigma$ error margin. Also in 2002, the same setup was used to measure the BRDF of a 2-inch *Spectralon* diffuser before and after degradation typical to space environment. The corresponding effect was modeled and the resulting model was implemented to the MERIS geometry.

- Finally, the TNO TPD BRDF measurement facility was validated in 2000 the frame of an inter-comparison measurement of the BRDF of a MERIS ESA diffuser with NASA GSFC.

8 REFERENCES

- 1. PO-RP-TPD-ME-0016, issue 1, MERIS phase 1 test diffuser calibration results.**
- 2. PO-RP-TPD-ME-0017, issue 2, MERIS QRR1 and QRR2 diffuser calibration results.**
- 3. PO-RP-TPD-ME-0018, Issue 2, MERIS FRR diffuser calibration results (Diffuser #18 and #19).**
- 4. PO-RP-TPD-ME-0019, Issue 1, Diffuser #21 and #23 calibration results.**
- 5. PO-TN-TPD-ME-0009, Issue 1, Investigation of the BRDF discontinuity observed in the spatial dependence of QRR1 and QRR2.**
- 6. PO-RP-TPD-ME-0020, Issue 1, MERIS additional characterization of ESA diffuser # 23.**
- 7. PO-RP-TPD-ME-0022, Issue 1, Additional characterization of the ESA MERIS diffusers.**
- 8. PO-RP-TPD-ME-0023, Issue 1, Modelisation of the degradation of a Spectralon diffuser in space conditions.**